



Truma UltraRapid Hot Water System

LPG and 230 V / 240 V Electric Storage Water Heater

(AUS) **Operating instructions**

Page 8

To be kept in the vehicle!

Page 4 **Installation instructions**



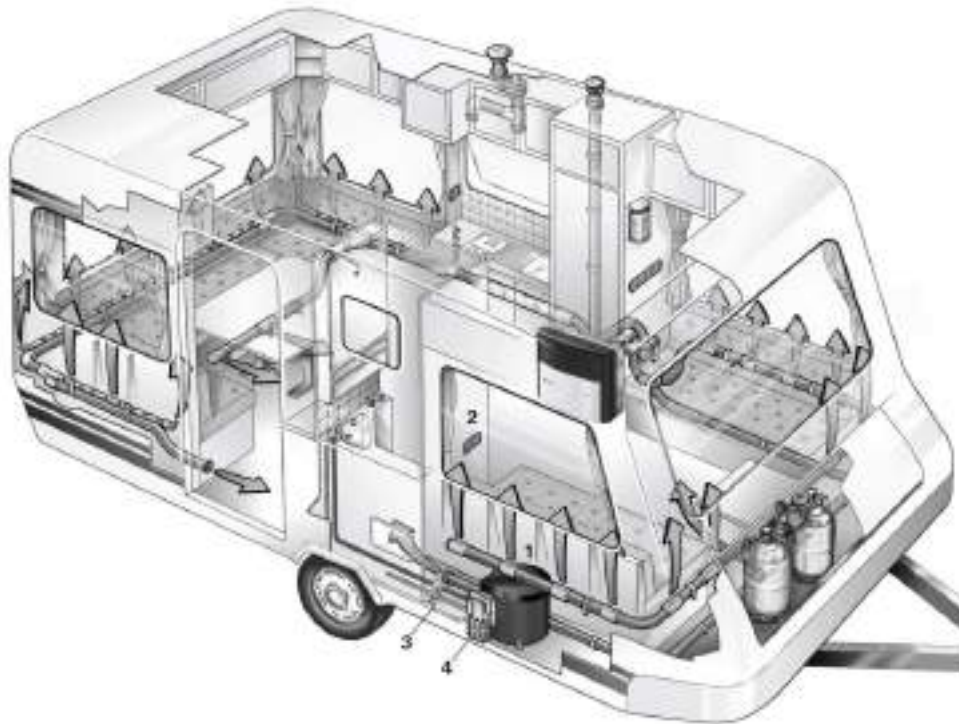

Fig. 1

Installation example

- 1 Truma UltraRapid HWS
- 2 Control panel
- 3 Drain valve
- 4 Cowl for combustion air intake and exhaust gas discharge

Table of contents

Symbols used	2
Model	2
General safety notes	3

Operating instructions

Filling the Truma UltraRapid HWS with water	4
Draining the water heater	4
Switching on gas operation	4
Switching off gas operation	4
4 Red indicator lamp "Fault"	5
Electrical operation – option – 230 V ~ / 240 V ~,	
1300 W / 1415 W (5.7 A / 5.9 A)	
5 Maintenance	5
Fuses	5
5 Fault	

finding	5
Technical data	5
6 Truma warranty policy	6
7 Installation instructions	
Data label	8
Intended use	8
Regulations	8
Water heater kit	8
8 Choice of location	8
8 Installation of the water heater	8
8 Water connection	9
9 Installation of the elbow water connectors	10
10 Installation of the drain valve	10
10 Installation of the pressure reducer	10
10 Water pipe routing	10
10 Gas connection	10
10 Installation of the control panel	11
11 Electrical connection 12 V V ~ – option –	12
12 Function check	12
12 Accessories	12
14 Wiring Diagram	14

Symbols used



The device must only be installed and repaired by an expert.



Symbol indicates a possible hazard.



Note containing information and tips.

Model

Truma UltraRapid Gas BGA 14

Truma UltraRapid Gas / Electric BGEA 14

General safety notes

The use of upright gas cylinders from which gas is **taken in the gas phase** is mandatory for the operation of gas regulators, gas equipment and gas systems. Gas cylinders from which gas is taken in the liquid phase (e. g. for fork lifts) must not be used, since they would result in damage to the gas system.

In the event of leaks in the gas system or if there is a smell of gas:

- extinguish all naked flames
- do not smoke
- switch off all appliances –shut off the gas cylinder
- open the windows and doors
- do not actuate any electrical switches
- have the entire system checked by an expert!



Repairs may only be carried out by an expert.

–This device may be used by children aged 8 years or above and by persons with reduced physical, sensory or mental capabilities or lack of experience and / or knowledge, only if they are supervised or have been given instruction with regard to the safe use of the device and have understood the potential risks. Children must not use the device as a toy.

–To avoid the risk of accidental resetting of the over-temperature guard, the device may not be supplied with power via an external contactor, such as a timer, nor may it be connected to a power circuit that is regularly switched on or off via a device.

Danger

Failure to operate the relief valve at least once every six months may result in the water heater

splitting. Continuous leakage of water from the valve may indicate a problem with the water heater!

–Water may drip from the discharge pipe of the pressure relief device and this pipe must be left open to the atmosphere.

–The pressure relief device is to be operated regularly to remove lime deposits and to ensure that it is not blocked.

–Any discharge pipe connected to the safety (pressure relief) valve is to be installed in a continuously downward direction and in a frost free ambient.

–Before accessing terminals, please ensure all supply circuits are disconnected (i.e. 230 V – 240 V and 12 V) and that the gas supply is securely turned off.

–Any work involving connection or interconnecting wiring must be carried out by a licensed electrician.

–Any modifications to the unit, including accessories and cowl, or the use of spare parts and accessories that are important to the operation of the system that are not original Truma parts and failure to follow the installation and operating instructions will void the warranty and release Truma from any liability claims. It also becomes illegal to use the appliance, and in some countries this even makes it illegal to use the vehicle.

–The operating pressure for the gas supply is 2.75 kPa (AUS – Propane) and must correspond to the operating pressure of the appliance (see data plate).

–LPG systems and pressure regulators must comply with the technical and administrative regulations of the country in which the appliance is used. For your own safety it is absolutely necessary to have the complete gas installation regularly checked by an expert (at least every 2 years). The vehicle owner is always responsible for arranging the gas inspection.

–Do not operate when travelling.

–Do not operate the water heater when refueling the vehicle and when it is in the garage.

–Items sensitive to heat (e. g. spray cans) must not be stored in the installation area, since excess temperatures may occur there under certain circumstances.

–During the initial operation of a brand new appliance (or after it has not been used for some time), a slight amount of fumes and a slight smell may be noticed for a short while.

Operating instructions

Always observe the operating instructions prior to starting! The vehicle owner is responsible for correct operation of the appliance.

 Before using the product for the first time, it is essential to flush the entire water supply through with clean warm water. Always mount the cowl cap when the water heater is not being operated! Drain the water heater if there is a risk of frost! **Warranty claims will not be accepted for frost damage.**

Always remove the cowl cover prior to operating the water heater!

If connecting to a central water supply (rural or city connection) or when using more powerful pumps, a pressure reducer must be used which prevents pressures of greater than 400 kPa occurring in the Truma UltraRapid HWS.

Filling the Truma UltraRapid HWS with water

Check that the drain valve in the cold water intake is closed: Lever should be in horizontal position, position (e).

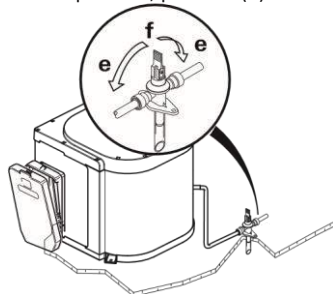



Fig. 2

e = Lever position "Closed" f = Lever position "Drain"

 You must operate the drain valve regularly to prevent lime scale and to ensure that it is not blocked.

Open hot tap in bathroom or kitchen, with pre-selecting mixing taps or single-lever fittings set to "hot".

Switch on power for water pump (main switch or pump switch).

Leave the tap open to let air escape while the water heater is filling. The heater is filled when water flows out of the tap.

Residues of frozen water can prevent filling if there is a frost. The water heater can be defrosted by switching on the heater for a short period (max. 2 minutes). Frozen pipes can be defrosted by heating the room.

 If just the cold water system is being used, without water heater, the heater tank is also filled up with water. In order to avoid damage through frost, water must be drained by means of the drain valve, even if the heater has not been used. As an alternative, two shut-off valves, resistant to hot water, can be fitted in front of the cold and hot water connection.

Draining the water heater

 If the vehicle is not used during periods of frost, it is essential that the Truma UltraRapid HWS be emptied.

Disconnect power for water pump (main switch or pump switch).

Open hot water taps in bathroom and kitchen.

Open drain valve: Lever in vertical position, position (f).

The water heater is now drained directly to the outside via the drain valve. Check that the water has been completely drained (14 litres).

Switching on gas operation

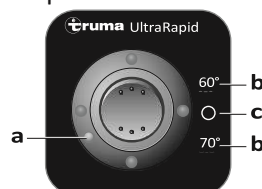



Fig. 3

a = Red indicator lamp "Fault" b = Water heater "On" 60 °C or 70 °C c = Water heater "Off"

 Never operate the water heater without water in it!

If the wall cowl is positioned close to an opening window (or hatch) – in particular directly under it – it must remain closed when the water heater is in use (see warning plate).

Remove cowl cover.

Open gas cylinder and open stop cock valve in the gas supply line.

Switch on water heater at the switch on the control panel (b).

When using the vehicle switches

Refer to operating instructions of the vehicle manufacturer or see switch labels.

If there is air in the gas supply line, it may take up to a minute before the gas is available for combustion. If the appliance switches to "Fault" during this time, switch off the appliance – wait 10 minutes – and switch on again!

Switching off gas operation

Switch off the water heater to position (c).

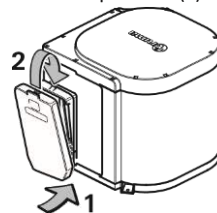



Fig. 4

If the water heater is not to be used for a longer period, mount cowl cover (non-observance of this point can lead to the function of the appliance being impaired through water, dirt or insects), close stop cock valve in the gas supply line and close the gas cylinder.

 Before setting off on any journey, fit cowl cap with the Truma UltraRapid HWS switched off. Please ensure that it is secure and has locked into place (risk of accident). Defective cowl caps must not be used.

Drain the water heater if there is a risk of frost! Warranty claims will not be accepted if this is ignored.

Red indicator lamp "Fault"

The red indicator lamp (a) lights up if there is a fault. For possible causes please refer to page 5 – "Fault finding". To unlock, switch off the appliance, wait 10 minutes, and switch on again.

Electrical operation – option –

230 V ~ / 240 V ~,

1300 W / 1415 W (5.7 A / 5.9 A)



The Truma UltraRapid HWS must not be operated with a time switch.

To operate the electric heating element, please insert the plug into the socket and then turn it on with the switch.

The electric heating element is operational when you can see the mark on the switch (g).

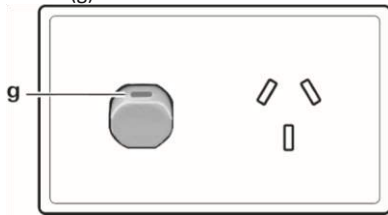

Fig. 5



Never operate the water heater without water in it!



The water temperature cannot be selected, automatic temperature limitation at approx. 70 °C! For a faster heating up period the appliance can be simultaneously operated with gas **and** electrical power.

Maintenance



Materials in the device which come into contact with water are suitable for use with drinking water (see manufacturer declaration: www.truma.com – Manufacturer Declaration).

We recommend the use of suitable normal commercial products for the cleaning, disinfection and care of the Truma UltraRapid HWS. Products containing chlorine are unsuitable.

In order to avoid the colonization of micro-organisms, heat up the Truma UltraRapid HWS to 70 °C at regular intervals.

Fuses

The water heater 12 V fuse is on the PCB on the water heater.

Important note

Only replace the miniature fuse on the PCB with a fuse of the same type: 1.6 A (slow action).

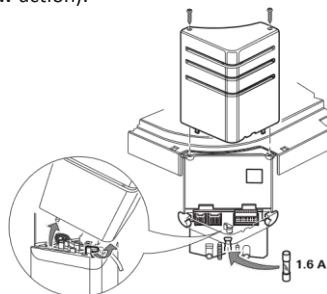

Manufacturer

Fig. 6



If there is a defect in the electronics, return the PCB well padded. If you fail to pack it correctly, the warranty shall no longer be valid.

Only use original Truma UltraRapid HWS - PCB as spare parts!

Fault finding

Gas operation

Symptom

Cause

When switching on, the heater does not operate.

– No 12 V supply voltage.

Check the power supply (operation voltage min. 10.5 V). Check the Truma UltraRapid HWS fuse (refer to maintenance "Fuses").

When switching on, the heater does not operate and the red lamp lights up

– Cowl cover fitted.
– Air in the gas supply.
– No gas supply.
– Incorrect gas pressure.

Remove cowl cover and / or clear any obstruction.

Check gas valves and gas cylinder.

To unlock (and purge air), switch off the appliance, wait 5 minutes, and switch on again.

Heater operates for a prolonged time and then thermostat has responded.

– Excess temperature
– thermostat has responded.

Check water level, refill if required (close drain valve). To unlock, switch off the appliance, wait 5 minutes, and switch on again.

Electrical operation

Symptom

Cause

When switching on, the heater does not operate.

– No 240 V supply voltage.
– Excess temperature
– thermostat has responded.

Connect the caravan to the site supply and / or check residual current circuit breaker.

Check water level, refill if required (close drain valve).

The electrical heating element is fitted with an excess temperature cut-out. In the event of a fault, switch off at the control panel, wait 10 minutes, then switch on again.

Water supply

Symptom

Cause

Water drips from the valve.

– Water pressure too high. safety valve.

Check water pressure (max. 400 kPa), use a pressure reducer when connected to central water supply.

When opening the cold water tap, hot water supply.

– Hot water flows back through the cold water supply.

Fit a non-return valve in the cold water supply (refer to installation instructions "Water connection").

If fault persists, please contact the nearest Dometic Service.

Dimensions

Technical data

P.O. Box 1252

85637 Putzbrunn / Munich

Germany

Protection type IP21

Water capacity

14 litres

Water pressure max. 400 kPa **Type of gas** LPG (Propane)

Test point pressure

2.75 kPa

Nominal input

4.7 MJ/h

Heat output

4.1 MJ/h

Gas consumption

90 g/h

Injector size

0.70 mm

Heating up time from approx. 20 °C up to approx. 65 °C

(14 litres)

Gas operation: approx. 45 min.

Electrical operation: approx. 40 min.

Gas and electrical operation: approx. 28 min.

Power consumption 12 V ---

Ignition: 0.160 A

Heating up: 0.12 A

Stand-by: 0.05 A

Power consumption 230 V \sim / 240 V \sim Heating up: 5.7

A / 5.9 A, 1300 W / 1415 W

Weight (empty) 14 litres

7.5 kg (BGA 14)

7.9 kg (BGEA 14)

AGA Approval-No

5801



5375

The right to make technical modifications is reserved!

Truma warranty policy

The warranty is given by

Dometic Pty Ltd, Building 3B,

Clayton Business Park,

1508 Centre Road, Clayton, Victoria, 3168,

Australia

for 24 months from the date of purchase against any defect arising from faulty materials or workmanship.

Repairs will be carried out during normal business hours only by Dometic Pty Ltd, or its duly authorised service agents, and are subject to the warranty conditions and exclusions hereunder.

Warranty conditions

- The company will only provide service on presentation of proof of purchase, on either the Truma product, or the Caravan / RV / Pleasure Craft in which the Truma product has been installed, to any authorised service agent. The purchaser must allow the service agent to photocopy the proof of purchase to facilitate his claim to the manufacturer.
- Warranty repairs can only be performed by authorised service agents and under no circumstances will Dometic reimburse repairs carried out by unauthorised persons. Tampering with any

Truma Gerätetechnik GmbH & Co. KG

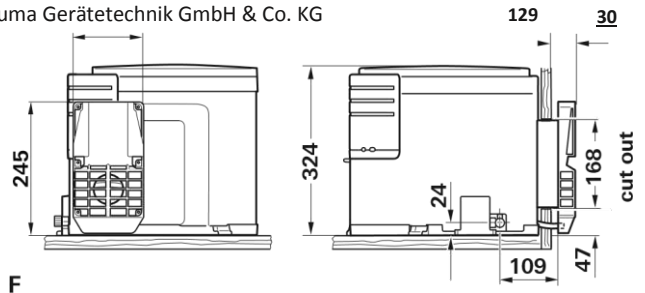

Fig. 7 F

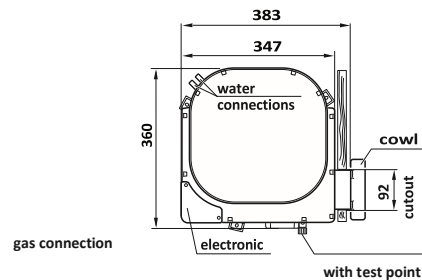

Fig. 8

All dimensions in mm.

part of the product by unauthorised personnel will automatically void the warranty.

- The product must be used solely for domestic purposes. If the product is used for commercial purposes the warranty is 6 months only.
- Where applicable, the products must be used on the appropriate electrical voltage, gas type and pressure, or fuel source.
- If at any time during the warranty period any part or parts are replaced with a part or parts not supplied or approved by Truma, this warranty shall immediately become void.

Important notice

Before calling a service technician please check carefully the operating instructions, warranty terms and conditions. If the product fails for any of the reasons detailed therein, or is faulty due to abuse, misuse or improper installation, then a service fee shall be charged to the purchaser.

If you have any queries regarding the interpretation of the warranty you should contact Dometic Pty Ltd.

Whilst this book represents service outlets at the time of printing, changes occur from time to time. Should you have any queries or wish to locate your nearest authorised service agent please contact Dometic Pty Ltd.

Warranty does not cover

Any heater which has been:

- (a) Subject to misuse, neglect, accident or alteration by any person.
- (b) Damaged or destroyed by fire, flood, act of God or other inevitable accident.
 - Fair wear and tear.
 - Damage from foreign substances such as dirt or liquid.
 - Travelling expenses or call out fee to and from authorised service agents premises.
 - Accommodation or Site Expenses.
 - Cleaning of the system or cleaning and adjustment of the gas system. This is considered to be a part of normal product maintenance.
 - Heater not operating or resultant damage to the unit because it has not been operated in a level position.
 - Freight cost of the appliance or parts, to or from, point of service or transit damage.
 - Dometic / Truma are not responsible for resultant loss or damage sustained by the purchaser.
 - Appliance not operating or resultant damage to the unit where the appliance has not been installed, ventilated, flued or operated in accordance with the manufacturer's instructions.

Apart from any warranties implied by the Trade Practices Act 1974 or any relevant State legislation all other warranties express or implied whether arising by virtue of statute or otherwise are hereby excluded.

Installation instructions



Installation of the unit may only be carried out by properly qualified professionals.

This appliance shall be installed in accordance with the manufacturer's installation instructions, local gas fitting regulations, municipal building codes, electrical wiring regulations, AS5601 "Gas Installations", any other statutory regulations and water supply regulations.

Data label

The data label is located on the top of the water heater.

This appliance is suitable for propane gas only, ensure that the available gas supply is suitable.

Intended use

This appliance has been designed for installation in caravans, motor caravans and other vehicles. It is not approved for installation in boats. Other forms of use are also possible following consultation with Truma.

Regulations

Any modifications to the unit, including accessories and cowl, or the use of spare parts and accessories that are important to the operation of the system that are not original Truma parts and failure to follow the installation and operating instructions will void the warranty and release Truma from any liability claims. It also becomes illegal to use the appliance, and in some countries this even makes it illegal to use the vehicle.

The operating pressure for the gas supply is 2.75 kPa (AUS – Propane) and must correspond to the operating pressure of the appliance (see data plate).

After it has been installed, the device must be disconnected from the power supply. It can be disconnected by ensuring that the power plug is accessible or by installing a switch in the fixed power supply installation.

When installing the appliance always observe the technical and administrative rules and regulations of the country in which the vehicle is to be registered for the first time!

Water heater kit

The water heater kit contains:

- 1 Assembled water heater
- 1 Cowl assembly with screws
- 1 Hot water connector (12 mm rigid piping)
- 1 Cold water connector (12 mm rigid piping) 1
- Drain valve (12 mm rigid piping)
- 1 Pressure reducer (12 mm rigid piping)
- 1 Wall switch (gas operation) with 3.0 m cable
- 1 Electric heating element (230 V ~ / 240 V ~) with 1.1 m mains cable and pre-fitted plug – **option** –
- 1 Installation template
- 1 Set literature

In order to guarantee complete emptying of the water, ongoing sealing tightness of the water connections and safety functions, **all enclosed parts must be used!**

Choice of location

Always install the appliance in such a way that it is easily accessible for service work at all times and can be easily removed and installed.

Locate the heater in such a way that the cowl can be mounted on the outside on a surface which is as straight and smooth as possible.

This outside surface must be exposed to wind from all directions and, if possible, there should be no trim strips or covers in this area, mount heater on an appropriate base, if necessary.

The cowl must be placed in such a way that the exhaust gas cannot find its way into the vehicle interior. For this reason, choose a location where there are no opening windows, skylights or ventilation openings directly above the cowl or within 50 cm on either side. If this is not possible, a warning plate must be placed on the inside of the window (or skylight) stating that it must be kept closed while the heater is operating. In this case refrigerator ventilations must be tight-sealed from the interior of the vehicle.

AUS:

Refer to AS5601 – Gas Installations, for location requirements of the flue terminal.

Installation of the water heater

Position template for cowl opening on the inside of the wall.

A = Bottom edge of heater

B = Lateral edge of heater

Drill 4 holes (C) with 10 mm dia. through the wall. Drill hole (E) with 15 mm dia. for condensation tube (also possible from the outside = F).

Position template on the outside of the wall. The markings (C) must be above the through-holes. Saw cut-out section for cowl (D) 92 x 168 mm.

If the distance between outside wall and heater is more than 35 mm, you must use the cowl extension VBO 2 (please refer to page 12) with an additional length of 50 mm. Saw out 100 x 176 mm along the dashed line.

If there are any cavities in the area of the cowl, pack these with pieces of wood so as to be able to tighten the screws.

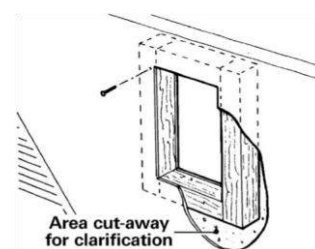

Fig. 9

Cut out trim strips or such on the vehicle or place supports beneath them so as to make the cowl lie flat.

Place a support beneath the heater if the walls are sloping. An angle of inclination of 10 degrees is not to be exceeded.

Insert heater with cowl body (1) through the wall cutout (2), allow approx. 5 mm to project out of the wall. Mount sealing frame (3 – the anti-twisting device ensures correct fitting!). Pre-drill holes for the 6 fastening bolts (4).

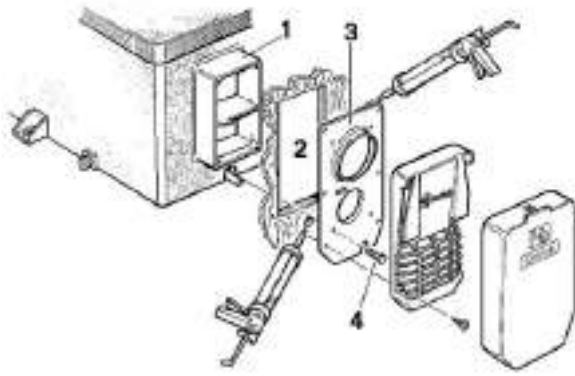

Fig. 10

Remove sealing frame (3) and coat with non-hardening mastic on the side facing the vehicle – do not use silicone!

! The sealing frame must be well sealed with respect to the front sides and the cross bars of the cowl body (1) as well as towards the outside wall!

Fasten sealing frame (3) to the cowl body using 4 self-tapping screws (4).

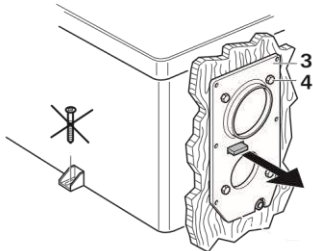

Fig. 11

! Screw the sealing frame (3) together with the cowl body (1) so the anti-twist device projects.

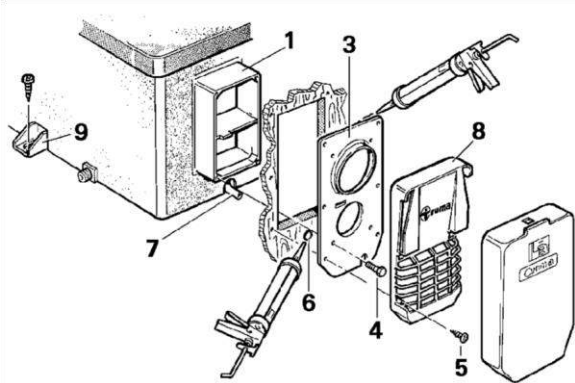

Fig. 12

Seal the gap between the hole (6) and the condensation tube (7) with non-hardening mastic – do not use silicone!

Mount the grille (8). Press the entire cowl assembly onto the vehicle wall and fasten with 6 screws (5).

Screw the Truma UltraRapid HWS securely to the floor of the vehicle with at least two shackle plates (9) with the screws provided, B 5.5 x 25, on suitable base (plywood panel, laminated wood strips or metal base).

Water connection

All pressure and submersible waterpumps can be used for operating the water heater.

! In order to guarantee complete emptying of the water and to prevent pressures of greater than 400 kPa occurring in the Truma UltraRapid HWS, the enclosed pressure

reducer (10), the enclosed water connectors (12 + 13) and the enclosed drain valve (14) must be used!

When using pressure pumps with high switching hysteresis, hot water may flow back through the cold water tap. To prevent backflow, we recommend that a non-return valve (nrV – not included in the scope of supply) be fitted between the outlet to the cold water tap and the drain valve.

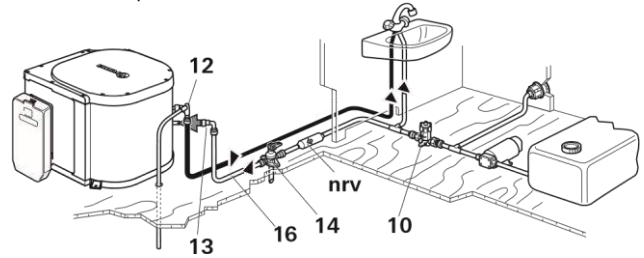

Fig. 13

i The supplied water connectors (12 + 13) and drain valve (14) have a 12 mm rigid piping connection (e. g. John Guest System). For connecting to rigid pipes with other diameters appropriate adapters (not included in scope of delivery) must be used.

As special accessories Truma supplies the water connectors (12 + 13) and drain valve (14) with a 10 mm / 3/8" diameter hose nipple (please refer to page 12).

! Route water pipes so that they are as short and free of kinks as possible (hose connections must be secured using hose clamps – also for cold water! – pressures of up to 400 kPa can occur in the drain valve – also with submersible pumps – because of the heat of the water and the resulting expansion).

! All hot water pipes should be routed in a descending manner to the drain valve! Otherwise there is no guarantee of protection from frost!

Installation of the elbow water connectors

Push elbow fitting without aeration valve (13) as far as possible onto the Truma UltraRapid HWS cold water connection tube (lower tube), and push the elbow fitting with built-in aeration valve (12) as far as possible onto the Truma UltraRapid HWS hot water connection tube (upper tube). Pull in the opposite direction to check that the elbow fittings are securely attached.

Slide venting hose with an outer diameter of 11 mm (20) onto the hose nozzle of the aeration valve (21) and route to the outside free of kinks. Radius of arc must not be less than 40 mm.

Cut off the venting hose about 20 mm below the vehicle floor at a 45° angle to the direction of travel.

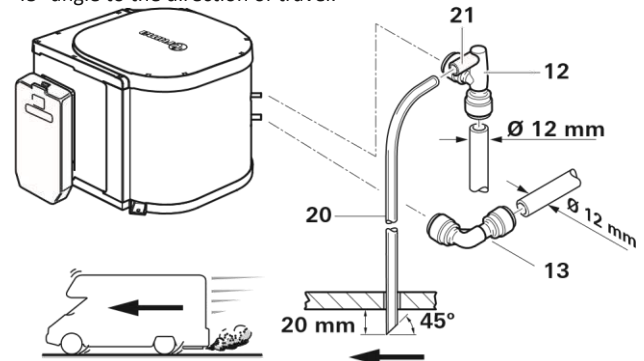

Fig. 14

In industrial bulk packs the water connections are preinstalled and have to be tightened after the water pipes have been connected. Please check for leaks before starting up for the first time.

Installation of the drain valve

Install the drain valve (14) at a place which is easily accessible, near the water heater.
The drain valve must be installed lower than the cold water connection of the Truma UltraRapid HWS. Drill a hole with 18 mm diameter and pass through the discharge tube. Fasten drain valve with two screws. The draining is to be directly to the outside at a position protected against splash water (apply splash guard, if necessary).

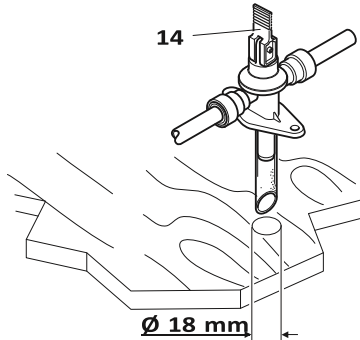

Fig. 15

Installation of the pressure reducer

The pressure reducer (10) must be fitted between the drain valve and water pump in accordance with the **direction of flow**. Fasten the pressure reducer to the floor.

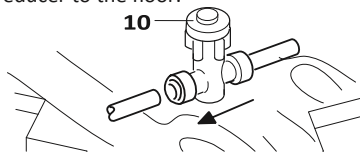

Fig. 16

Water pipe routing

Connect the cold water supply (15) via the pressure reducer (10) to the drain valve (14).

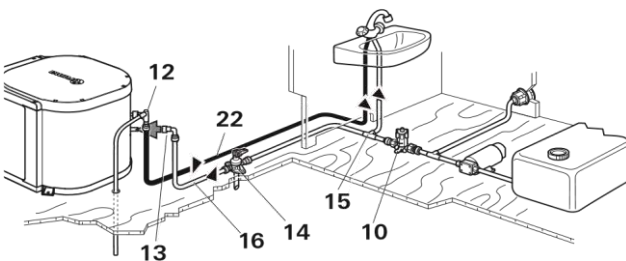

Fig. 17

Make a connection (16) for cold water supply between drain valve (14) and elbow (13 – lower pipe) on water heater.

Route the hot water pipe (22) from the elbow with integrated breather valve (12 – upper pipe) to the hot water appliances.

Gas connection

Refer to AS5601 – Gas Installations, for gas pipe sizing.

The gas inlet connection is a SAE 45° Flare 1/2 - 20UNF type.

For connection to 8 mm steel piping Truma provides an adapter UNF 1/2 in. x RVS 8, part no. 70020-02700.

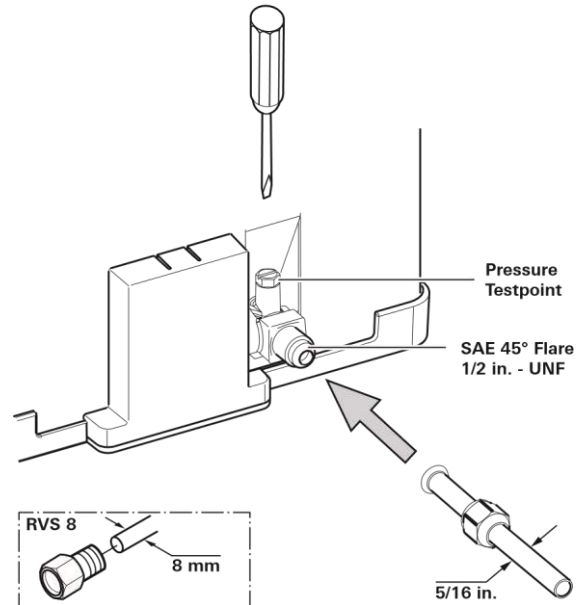

Fig. 18

Before connecting to the water heater make sure that the gas lines are free from dirt, chips and such!

Route the pipes in such a way that the appliance can be removed again for servicing.

Before starting up for the first time, verify the correct installation in accordance to the requirements of AS5601 (check for gas leaks and check the gas pressure). Do not check for gas leaks with a naked flame.

Installation of the control panel

! When using control panels which are specific to the vehicle or the manufacturer, the electrical connection must be established in accordance with the Truma interface descriptions (refer to Electrical connection 230 V ~ / 240 V ~). Any modification made to the Truma components pertaining to this will void the warranty and exclude any liability claims. The installer (manufacturer) is responsible for providing usage instructions for the user as well as for identification printing on the control panels.

When selecting the location, bear in mind that the control panels must not be subjected to direct radiant heat. Length of connection cable 3 m. If required, a cable extension of 5 m can be supplied (refer to page 12).

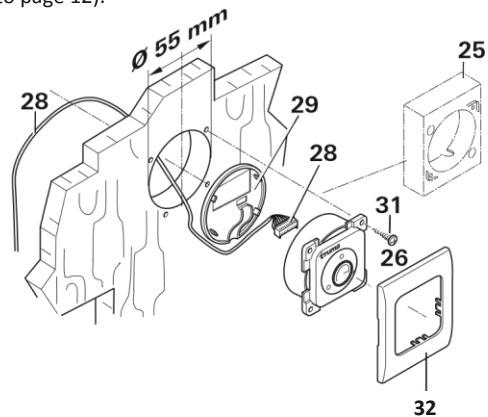

Fig. 19

Drill a hole with diameter 55 mm.

Plug the control panel cable (28) to the control panel for gas operation (26) and then fit on the rear cover cap (29) as a stress-relieving device.

Push the cable through to the rear and lay the connection cable (28) to the Truma UltraRapid HWS.

Lay the connection cable with the orange multipole connector (28) to the 12 V control electronics unit (for connection

Electrical connection 12 V ---

Disconnect device from power supply before starting to work on electrical components. Switching off at the control panel is insufficient!

The device must be disconnected from the on-board power supply when electric welding work is being carried out on the vehicle body.

 Reversing the polarity of the connections will result in a risk refer to Electrical connection 12 V).

Secure control panel with 4 screws (31) and fit the cover frame (32) on it.

 If a flush installation of the control panel is not possible, use the surface-mounting frame (25) as supplied.

of cable fire. Any warranty or liability claims will also be invalidated.

Push the control panel cable connector (28a) onto the control board.

In order to attach the cable (28) securely, route it through the cable guide (28b).

The 12 V electrical connection is made at the clamp (35).

orange = positive 12 V blue = negative

This is done by pressing from above with a small screwdriver and pushing the cable in from the front.

Connect to the fuse-protected on-board power supply (central electrical system 5 – 10 A) using a 2 x 1.5 mm² cable.

Connect negative line to main ground connection. For lengths of over 6 m, use a 2 x 2.5 mm² cable. If the equipment is connected directly to the battery, the positive and negative lines must be protected. Screw the cover (34) back on.

If necessary, remove the outer cable sheathing at the cover leadthrough.

No other 12 V consumers must be connected to the supply line.

The boiler fuse (36), 1.6 A, (slow-acting) is on the control board (see Fig. 6).

Fasten the electronics cover with screws (34).

Electrical connection 230 V \sim / 240 V \sim – option –

 All electrical work and permanent wiring must be carried out by a qualified person and in accordance with the standards AS/NZS 3000, AS/NZS 3001 and all local codes and regulatory authority requirements.

The electric heating element in the water heater is supplied with a mains cable and fitted 3-pole, earthed plug (in compliance with the standard AS/NZS 3112/2000).

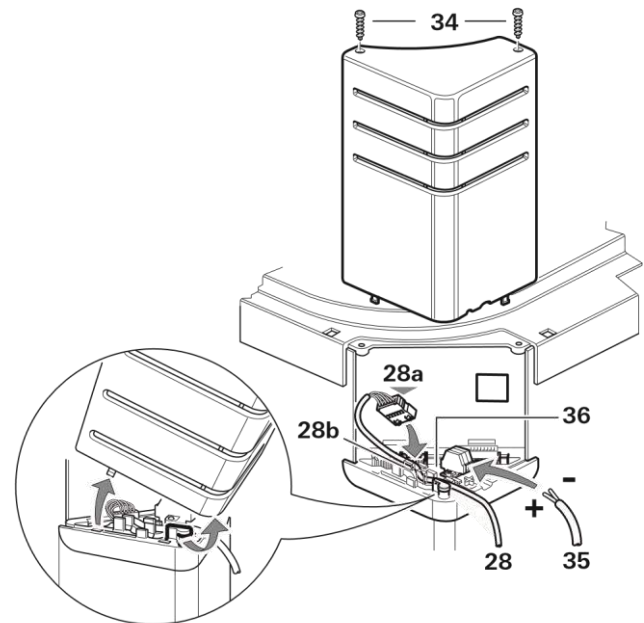



Fig. 20

 When power packs or power supply units are being used, note that the regulated output voltage is between 11 V and 15 V and the alternating current ripple is < 1.2 Vpp.

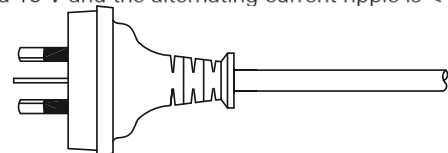



Fig. 21

In order to operate the element the manufacturer of the vehicle has to supply and install a socket with switch (2-pole separation) which is approved in Australia and earthed.

 All cables must be secured with cable clips.

Cables must be in accordance with the technical rules and regulations of the country in which the vehicle is to be registered for the first time.

Function check

After installation, check gas supply line for leaks in accordance with the pressure drop method. Following this, check the function of the appliance as specified in the operating instructions, in particular, check that the water drains properly. **Warranty claims for frost damage will not be accepted.**

Never operate the water heater without water. It is, however, possible to briefly check the electrical function without water. Always observe the operating instructions prior to operation!

The operating instructions and completed warranty card are to be given to the owner of the vehicle.

Accessories

Drain valve and water connectors for flexible water hoses

34020-63900	Hot water connector, 10 mm
34020-16900	Cold water connector, 10 mm
70141-02	Drain valve (280 kPa), 10 mm

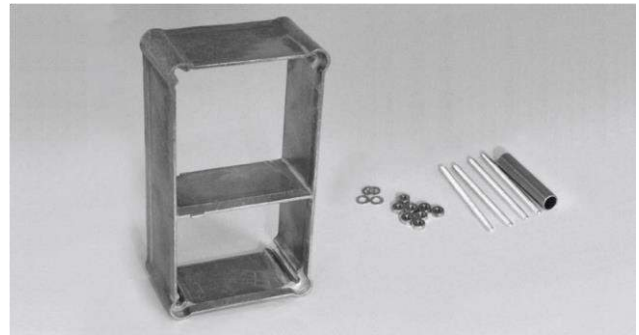

Fig. 22

Cowl extension for wall thicknesses over 35 mm

70131-00	Cowl extension VBO 2
----------	----------------------

Fig. 23



Control panel extension cable

70000-53500	Control extension cable 5 m
-------------	-----------------------------

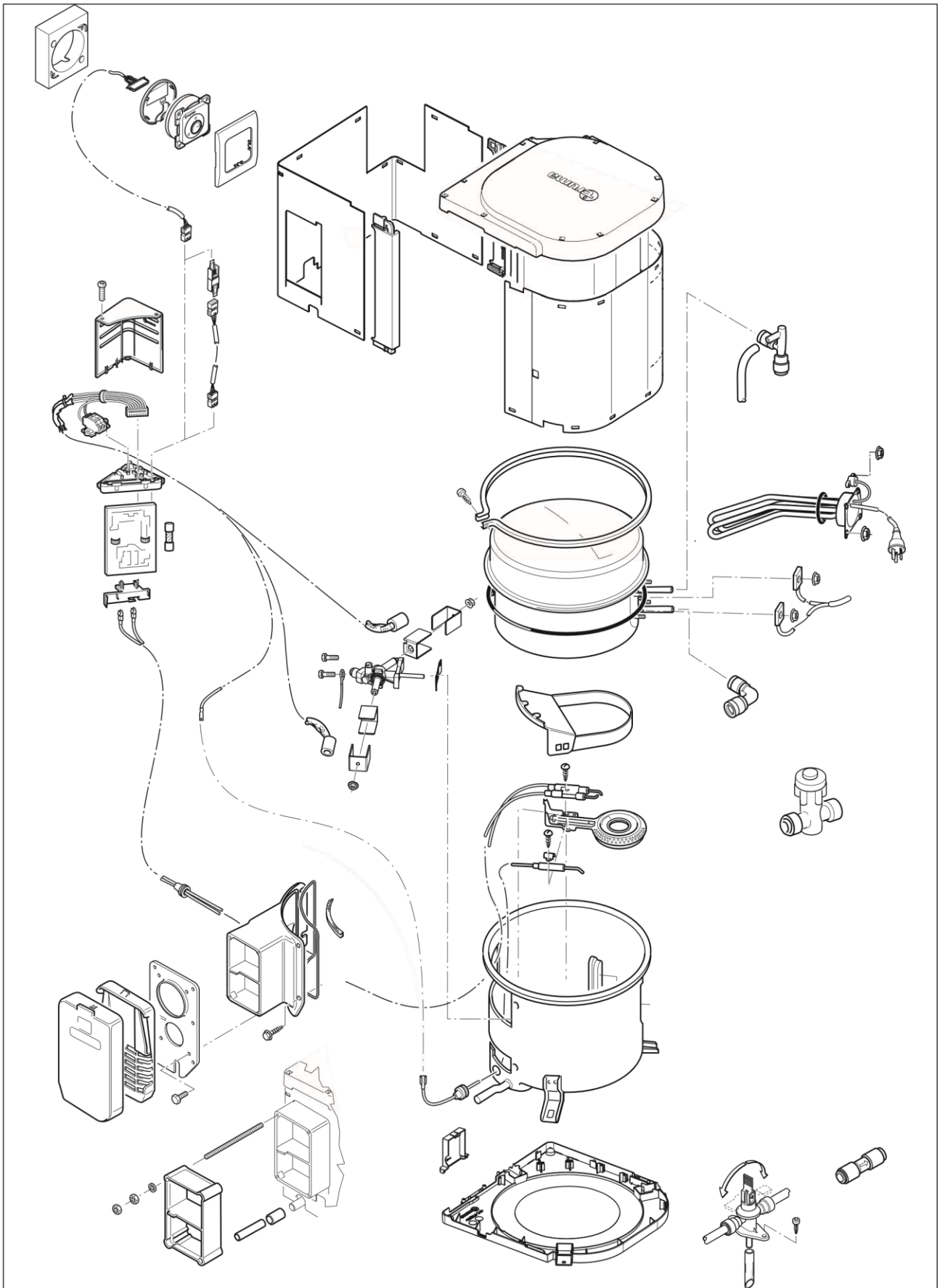

Fig. 24

Surface-mounting frame (not illustrated)

40000-52600	
-------------	--

BGA 14 / BGEA 14 LPG (Propane) and 230 V / 240 V Electric Storage Water Heater



When ordering spare parts, please always state the serial number and year of manufacture.

Wiring Diagram

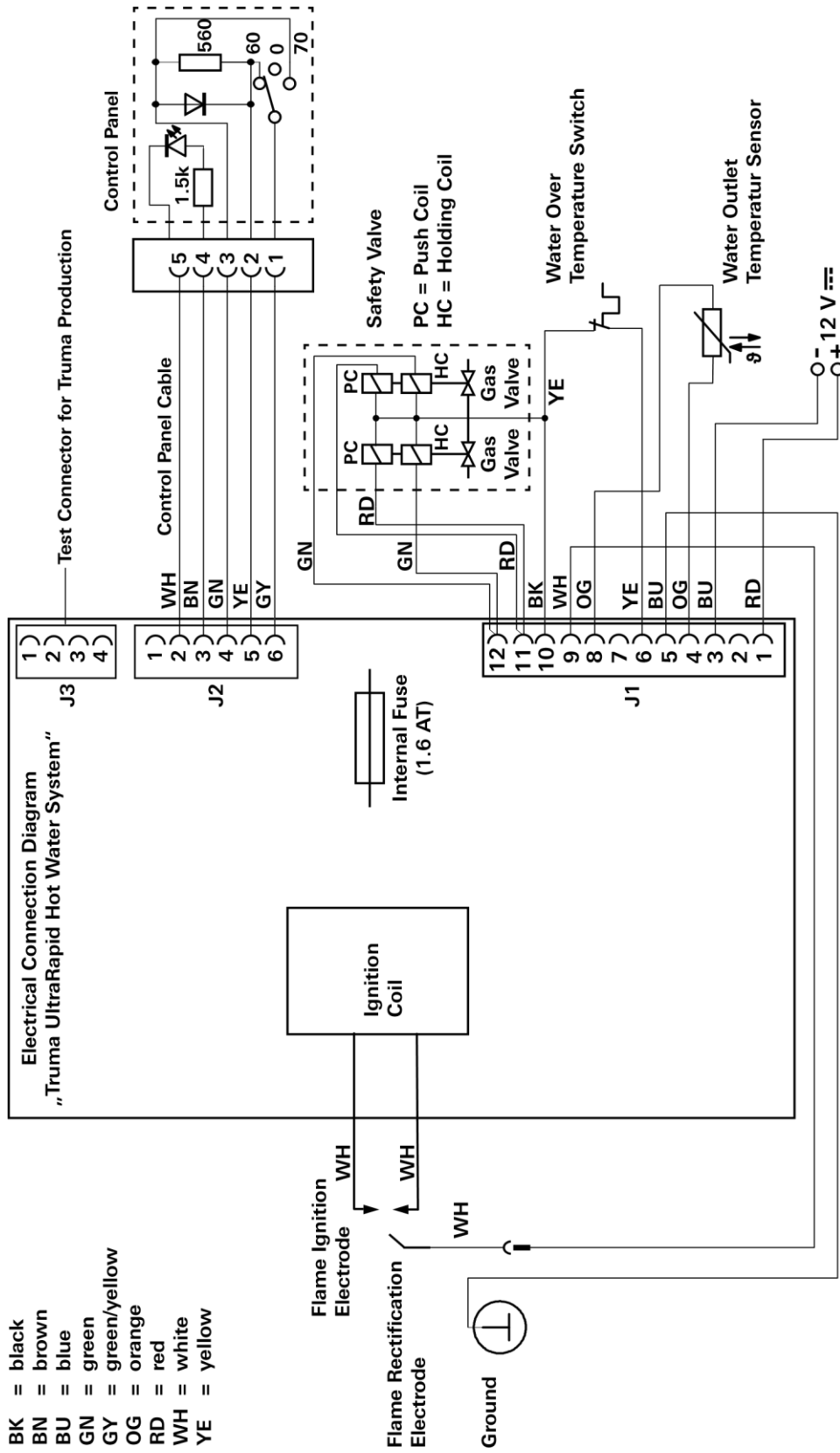

Therighttomaketechnicalmodificationsisreserved!

In Australia, always notify the Dometic Service Centre if problems are encountered; in other countries the relevant service partners should be contacted (www.truma.com).

Having the equipment model and the serial number ready (see type plate) will speed up processing.

Dometic Pty
Ltd
Building
3B,

C
l
a
y
t
o
n
B
u
s
i
n
e
s
s
p

ark 1508 Centre Road
Clayton, Victoria, 3168
Australia

Service (Australia)

Telephone: +61 (0)3 92 39 10 50 Facsimile: +61 (0)3 92 39 10 99